

## DLX & DLXB MA/AD

### Analogue dosing pump with manual flow rate regulation

The **DLX MA/AD** model consists of series of metering pumps enabling manual regulation by knob

#### General Features

- Double Manual regulation by knob
- Selectable regulation range: 0-20% or 0-100%
- Level sensor input (on request)
- Anti-acid plastic casing
- IP65 protection degree
- Wall (DLX) and Foot mounted (DLXB):
- Standard pump head: PVDF body, PTFE diaphragm, ceramic balls, FPM seats\*
- Power Supply: 220-240V\*\*
- Strokes frequency:
  - 120 strokes/min (from 1l/h to 15l/h)
- CE and CSA certified



*\*different configurations available upon request*

*\*\*other power supplies available on request*



#### PVDF-FPM Standard Kit

ALL DLX are supplied with a standard **PVDF-FPM installation kit**, made up of 2m discharge PE tube (4x6mm), 2m suction + 2m bleeding PVC crystal tube (4x6mm), PVDF foot-filter, PVDF injection valve. Other configurations are available upon request.

### Technical Features

Version	Flow Rate l/h (US GI/h)	Max Pressure Bar - PSI	Max frequency (imp./min)	Injection Volume (cc per stroke)	Standard Power Supply (Volts -Hz)	Power consumpti on (Watts)	Net Weight (Kg)
<b>0115</b>	1 (0.26)	15	120	0,14	230V - 50-60 Hz	37	2.3
	2 (0.53)	10		0,28			
	3 (0.78)	5		0,42			
<b>0507</b>	5	7	120	0,69	230V - 50-60 Hz	37	2.3
	6	5		0,83			
	8	2		1,11			

Pressure (bar) – Flow Rate (l/h) Chart

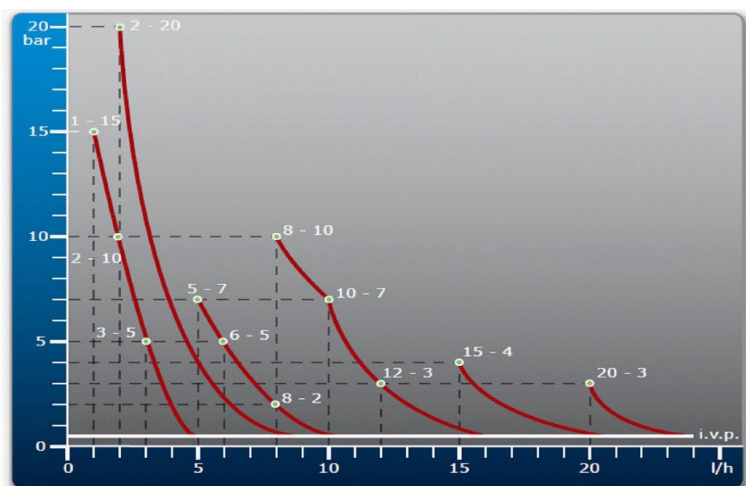

Overall Dimensions

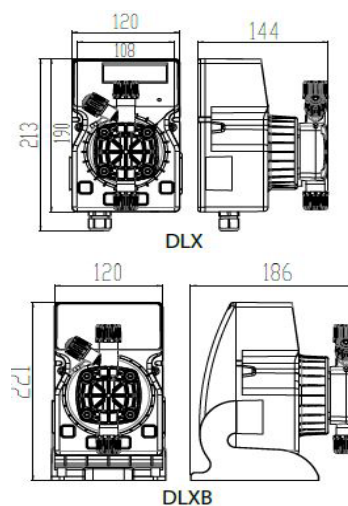

CODE	DESCRIPTION
PLX232225E	DLX MA/AD 1 - 15
PLX230385E	DLX MA/AD 5 - 7

CODE	DESCRIPTION
PBX232225E	DLXB MA/AD 1 - 15
PBX230385E	DLXB MA/AD 5 - 7